



B3641

Patent Number 6,532,815

ORDERING EXAMPLE

Please include the following:

- Gage Series
- Sight Opening (1-1/2" to 12-1/2")
- Fractional Portion of Centerline Length
- Mounting Kit
- Seal Material
- Gage Description

Example below: (B3641-10516BA1W) a round nylon level gage, short elbow, 5-1/2" centerline length, Buna-N seals with 1/8 NPT shank size.

B 3 6 4 1 - 1 0 5 1 6 B A 1 W

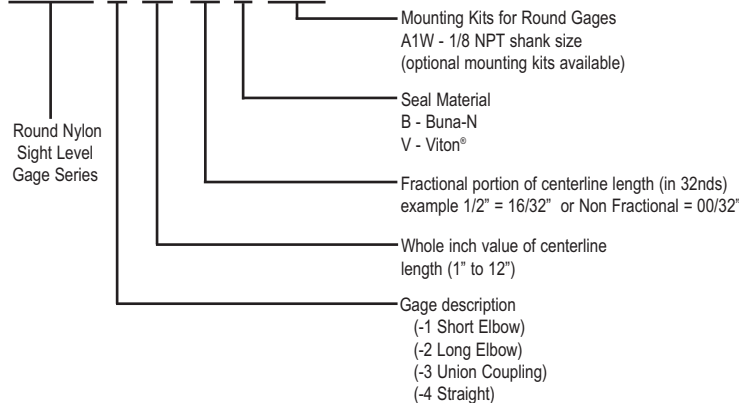

SHORT/LONG ELBOW GAGES are made for applications requiring horizontal inlets.

UNION COUPLING GAGES are made for applications requiring horizontal inlets and where clearance from obstructions do not permit rotating the gage for mounting.

STRAIGHT LEVEL GAGES are made for applications requiring vertical inlet and permitting direct mounting for quick response of fluid level.

These gages are made of tough, transparent, Trogamid® nylon bodies. They allow visual observation of liquid level and liquid clarity from all sides and angles. The transparent sights are compatible with many fluids, and they will retain their clarity through various temperature changes. The tough Trogamid® nylon can withstand a tremendous amount of duress, thus eliminating the hazards of glass breakage experienced on conventional designs.

The gages are used on tanks, reservoirs, hydraulic equipment, presses, large motor bearings, pillow blocks, and in other applications where it is necessary to guard against a low liquid level.

SPECIFICATIONS:

- Pressure: 125 P.S.I. Max.
- Temperature: 205° F. Max.
- End Blocks: Aluminum Alloy
- Sight: Round Nylon (Trogamid®)
- Seals: Buna-N (standard)
- Mounting Kits: Aluminum & Plated Steel

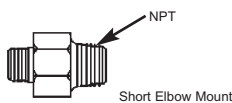
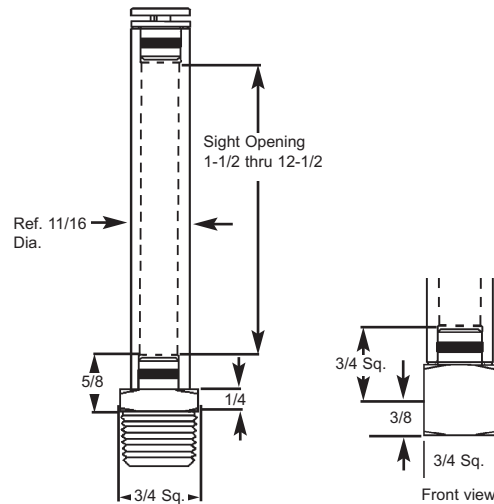

Short Elbow Mount

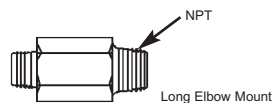

Long Elbow Mount

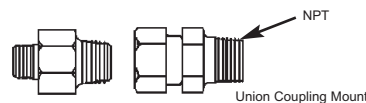

Union Coupling Mount

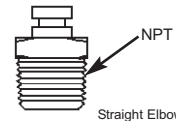

Straight Elbow Mount

Short Shank				Long Shank				Union Coupling				Straight			
1/2 NPT	3/8 NPT	1/4 NPT	1/8 NPT	1/2 NPT	3/8 NPT	1/4 NPT	1/8 NPT	1/2 NPT	3/8 NPT	1/4 NPT	1/8 NPT	1/2 NPT	3/8 NPT	1/4 NPT	1/8 NPT
A4W	A3W	A2W	A1W	A4W	A3W	A2W	A1W	A4W	A3W	A2W	A1W	A4W	A3W	A2W	A1W

Viton is a registered trademark of Dupont Dow Corp.
Trogamid is a registered trademark of Degussa AG