

New PurgeX® Chain Trolley Lubricator

The Chain Trolley Lubricator utilizes our patented PurgeX® pump technology to deliver precise amounts of lubricant to chain pins and open-faced trolley wheel bearings on overhead conveyors. The Chain Trolley Lubricator greatly reduces friction and extends conveyor life while reducing maintenance requirements. This unit also minimizes the operational and safety problems that result from inadequate lubrication, such as erratic conveyor operation, excessive noise and danger to product and personnel.

The Chain Trolley Lubricator attaches to a beam via clamps without additional machining to the beam. Simple electronics and nozzles specifically designed for this application react instantaneously and deliver lubricant where needed. "Wing style" construction allows the unit to handle irregularities in trolley position. Reversible component enclosure and adjustable nozzles allow for use on multi-directional chains and at variable speeds. The unit can be mounted on a horizontal, radius or inclined section of a beam.

The design and manufacturing of our Chain Trolley Lubricator is to the highest standards. Quality craftsmanship, combined with rugged and durable components, ensure long-term dependability and repeatability. In lab tests our PurgeX® pumps have achieved more than 360 million cycles without appreciable wear or failure. Oil-Rite "The First Time®"

Chain Trolley Lubricator Benefits

- Easy to install, adjust and maintain
- No beam modification necessary
- Extend the life of expensive conveyor systems
- Reduce downtime and maintenance costs
- Reduce surging and swaying of conveyor system

PurgeX® Pumps Features

- No priming necessary (positive inlet suction)
- Purges entrained air (will not vapor lock)
- Suck-Back feature (no after drip) from outlet
- Less than 1/1000th ml per cycle achievable

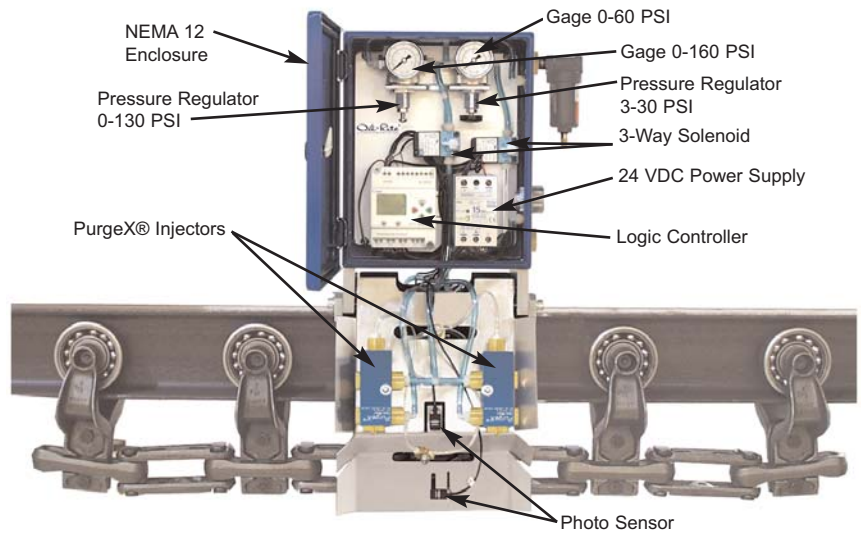

Patent Number 6,478,115

SPECIFICATIONS

PurgeX® Pumps Specifications	
Liquid delivery per cycle per pump	0 to .012 cu. in., adjustable
Temperature range	-15° F to 180° F
Air pressure required	40-120 psi
Piston ratio	9:1
Piston diameter and stroke	.250 diameter by 250 stroke (in.)

ORDERING EXAMPLE:

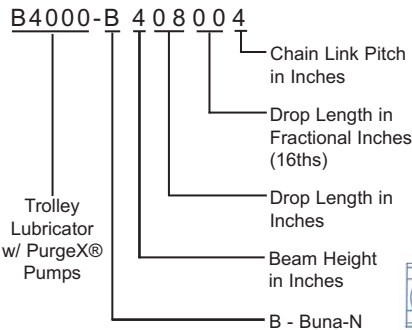

Example: Trolley Lubricator with PurgeX® Pumps, Buna Seals, 4" Beam, 8" Drop and 4" Chain Link.

